



www.mazzer.com



MAJOR ELECTRONIC





COLOURS



**MACINADOSATORE
MAJOR ELETTRONICO**

REGOLAZIONE DI MACINATURA
MICROMETRICA CONTINUA

- Macinatura istantanea
- Regolazione elettronica della dose
- Ventilazione elettronica

CARATTERISTICHE TECNICHE:

Potenza	650 Watt
Macine (rif. 151A)	Ø 83 mm
Giri macine	1400 (50 Hz) g/min 1600 (60 Hz) g/min
Capacità contenitore caffè in grani	1,8 Kg
Peso netto	20 Kg

**GRINDER-DOSER
MAJOR ELECTRONIC**

STEPLESS MICROMETRICAL
GRINDING ADJUSTMENT

- Grinding on demand
- Electronic dose adjustment
- Ventilation with electronic control

CARATTERISTICHE TECNICHE:

Power	650 Watt
Grinding blades (ref. 151A)	Ø 83 mm (3¼ inches)
Grinding blade speed	1400 (50 Hz) r.p.m. 1600 (60 Hz) r.p.m.
Coffee-bean container capacity	1,8 Kg (4 lbs)
Net weight	20 Kg (44 lbs)

**MOULIN DOSEUR
MAJOR ÉLECTRONIQUE**

RÉGULATION DE MOUTURE
MICROMÉTRIQUE CONTINUE

- Mouture instantanée
- Réglage électronique de la dose
- Ventilation électronique

CARACTÉRISTIQUES TECHNIQUES:

Puissance	650 Watt
Meules (réf. 151A)	Ø 83 mm
Tours meules	1400 (50 Hz) tr/min 1600 (60 Hz) tr/min
Contenance de la trémie	1,8 Kg
Poids net	20 Kg

**DOSIERMÜHLE
MAJOR ELEKTRONISCH**

STUFENLOSE MIKROMETRISCHE
MAHLREGELUNG

- Augenblickliches Mahlen
- Elektronische Einstellung der Dosis
- Elektronisch-kontrollierte Lüftung

TECHNISCHE DATEN:

Leistung	650 Watt
Mahlscheiben (Kennziffer 151A)	Ø 83 mm
Mahlscheibenumdrehungen	1400 (50 Hz) r.p.m. 1600 (60 Hz) r.p.m.
Kapazität des Bohnenbehälters	1,8 Kg
Nettogewicht	20 Kg

**MOLINO DOSIFICADOR
MAJOR ELECTRÓNICO**

REGULACIÓN MOLIENDA
MICROMÉTRICA CONTINUA

- Molidura instantánea
- Regulación electrónica de la dosis
- Ventilación electrónica

DATOS TÉCNICOS:

Potencia	650 Watt
Fresas (ref. 151A)	Ø 83 mm
Revoluciones fresas	1400 (50 Hz) r.p.m. 1600 (60 Hz) r.p.m.
Capacidad de la tolva	1,8 Kg
Peso neto	20 Kg

**MOINHO DOSEADOR
MAJOR ELECTRÓNICO**

REGULAÇÃO DA MOAGEM
MICROMÉTRICA CONTINUA

- Moagem instantânea
- Regulação electrónica de dose
- Ventilação electrónica

DADOS TÉCNICOS:

Potencia	650 Watt
Mós (ref. 151A)	Ø 83 mm
rotações dos mós	1400 (50 Hz) r.p.m. 1600 (60 Hz) r.p.m.
Capacidade tremonha	1,8 Kg
Peso líquido	20 Kg

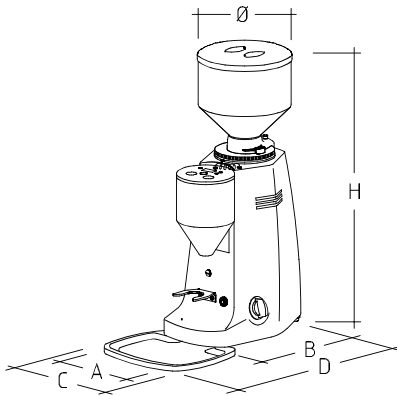

	mm	inches
A	212	8 ¼
B	292	11 ½
C	240	9 ½
D	455	18
H	635	25
Ø	212	8 ¼

CERTIFICATIONS



• Il costruttore si riserva la facoltà di apportare quelle modifiche tecniche che si rendessero necessarie senza preavviso. • The manufacturer reserves the right to change specifications without notice. • Le constructeur se réserve le droit d'effectuer des modifications sans aucun préavis. • Der Hersteller vorbehaltet sich den technischen Daten warnunglos zu ändern. • El constructor se reserva el derecho de efectuar sin previo aviso las modificaciones que considere oportunas en interés de mejoras técnicas en sus fabricados. • O constructor reserva-se o direito de modificar sem aviso previo as máquinas tratadas neste manual.

www.mazzer.com

MAZZER LUIGI s.r.l. Via Moglianese, 113 - 30037 Gardigliano di Scorzè (VE) - Italy
Tel. +39 041 5830200 - +39 041 5831300 - Fax +39 041 5830060 - E-mail: mazzer@mazzer.com - C.F. e P. IVA 00165200270





>



61
U A

